

HD 100 D 25

25 mm - 1"

DOME TWEETER

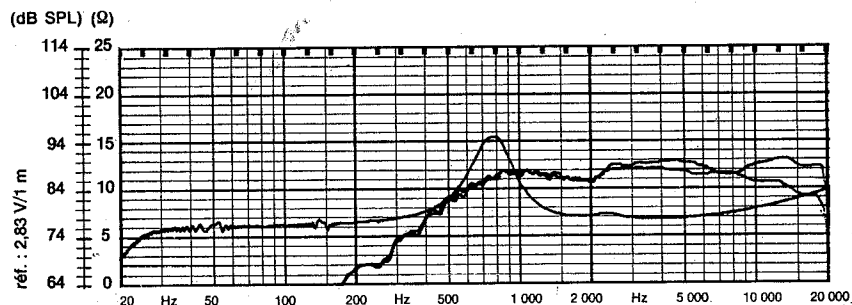
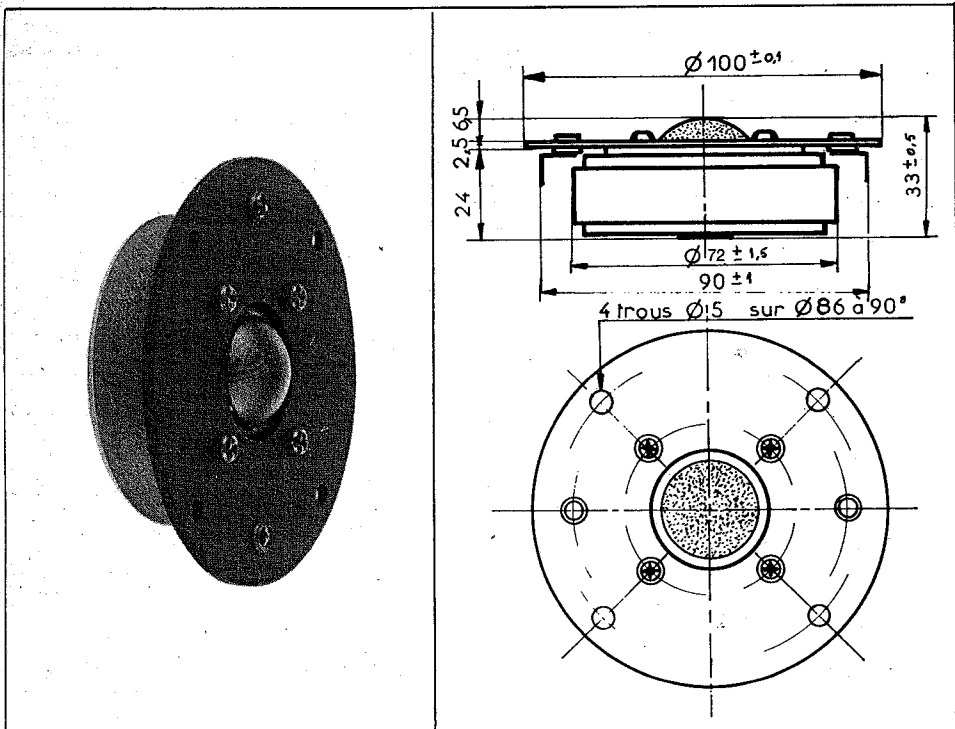

RESPONSE CURVE ON AXIS AND 30° OFF AXIS - IMPEDANCE CURVE

25 mm impregnated fabric soft dome. Perfect linearity coupled with absence of coloration accounts for its high reputation for reproducing natural sound. Also available with protection grill.

HD 100 D 25

25 mm - 1"

TECHNICAL SPECIFICATION	SYMBOL	VALUE	UNIT
Nominal impedance	Z	8	Ω
Minimum impedance	Z_{min}	6,8 @ 4 000 Hz	Ω
DC resistance	R_{sec}	5,8	Ω
Voice coil inductance	L_{BM}	75	μH
Resonant frequency	f_s	800 \pm 120	Hz
Suspension compliance	C_{MS}		mN^{-1}
Mechanical Q factor	Q_{MS}		
Electrical Q factor	Q_{ES}		
Total Q factor	Q_{TS}		
Mechanical resistance	R_{MS}		$kg s^{-1}$
Moving mass	M_{MD}	0,325 . 10 ⁻³	kg
Emissive diameter of the diaphragm	D	0,028	m
Effective piston area	S_D	0,62 . 10 ⁻³	m ²
Voice coil diameter	d	25,4	mm
Voice coil former		Aluminium	
Voice coil length	h	3	mm
Voice coil layers	n	1	
Flux density	B	1,47	T
Flux in the Gap	ϕ	0,352 . 10 ⁻³	Wb
Magnetic energy	W	0,135	Ws
Force factor	BL	2,97	NA ⁻¹
Gap volume	V_E	0,157 . 10 ⁻⁶	m ³
Height of the Gap	H_E	3	mm
Diameter of magnet	ϕA	72	mm
Height of magnet	B	16	mm
Weight of magnet		0,240	kg
Mass of speaker		0,530	kg
Characteristic efficiency level :			
1 W, pink noise, weighted	η	89 (TW)	dB SPL
Nominal power handling		50/5 kHz	W
Acceleration factor	Γ	9138	$ms^{-2} A^{-1}$